

CirCon⁺/TemCon⁺ - Thermostatic Valves for Domestic Water

Application

CirCon⁺ and TemCon⁺ are control valves designed for domestic hot water installations with circulation.

The valves automatically control the temperature of the water that circulates through the valves. Thus the thermal balance is ensured throughout the domestic hot water system. The valve is adjusted on a scale to a desired temperature in the interval between 37°C and 65°C.

TemCon⁺ is equipped with a by-pass located outside the thermal part of the valve.

So, TemCon⁺ is suited for hot water installations with bacterial problems, e.g. Legionella. Here a procedure of raising the temperature of the water to between 70°C and 80°C is carried out at certain intervals.



Advantages

CirCon⁺ and TemCon⁺

- The thermostatic element is located out of contact with the circulating water, and its dry location prevents scale problems.
- The setting of the valves is stepless between 37°C and 65°C at an accuracy of +/- 2°C.
- Each valve is calibrated separately.
- The valves are coated with tin/nickel, which is an anti-corrosive coating.
- Wide range of couplings.

TemCon⁺:

- By-pass for high temperature operation from 70°C to 80°C.
- By-pass adjustment occurs by hand or actuator.

CirCon⁺/TemCon⁺ - Thermostatic Valves for Domestic Water

CirCon⁺ Thermal control

CirCon⁺ controls on the basis of the temperature of the water that circulates through the valve. If the valve is set to a temperature of e.g. 50°C, and the temperature of the circulating water is under 50°C, the valve opens. If the temperature is over 50°C, the valve closes.



CirCon⁺ fem./fem. with scale and built-in isolation ball valve.



CirCon⁺
Temperature setting between 37°C and 65°C.
Remove the cap, and the temperature is easily set e.g. by a screwdriver as shown here.



Frese no. 47-2815: CirCon⁺ with press-couplings, and Frese no. 47-2809: CirCon⁺ with Cu-couplings.
Ready for installation!

CirCon⁺/TemCon⁺ - Thermostatic Valves for Domestic Water

Application Example - CirCon⁺

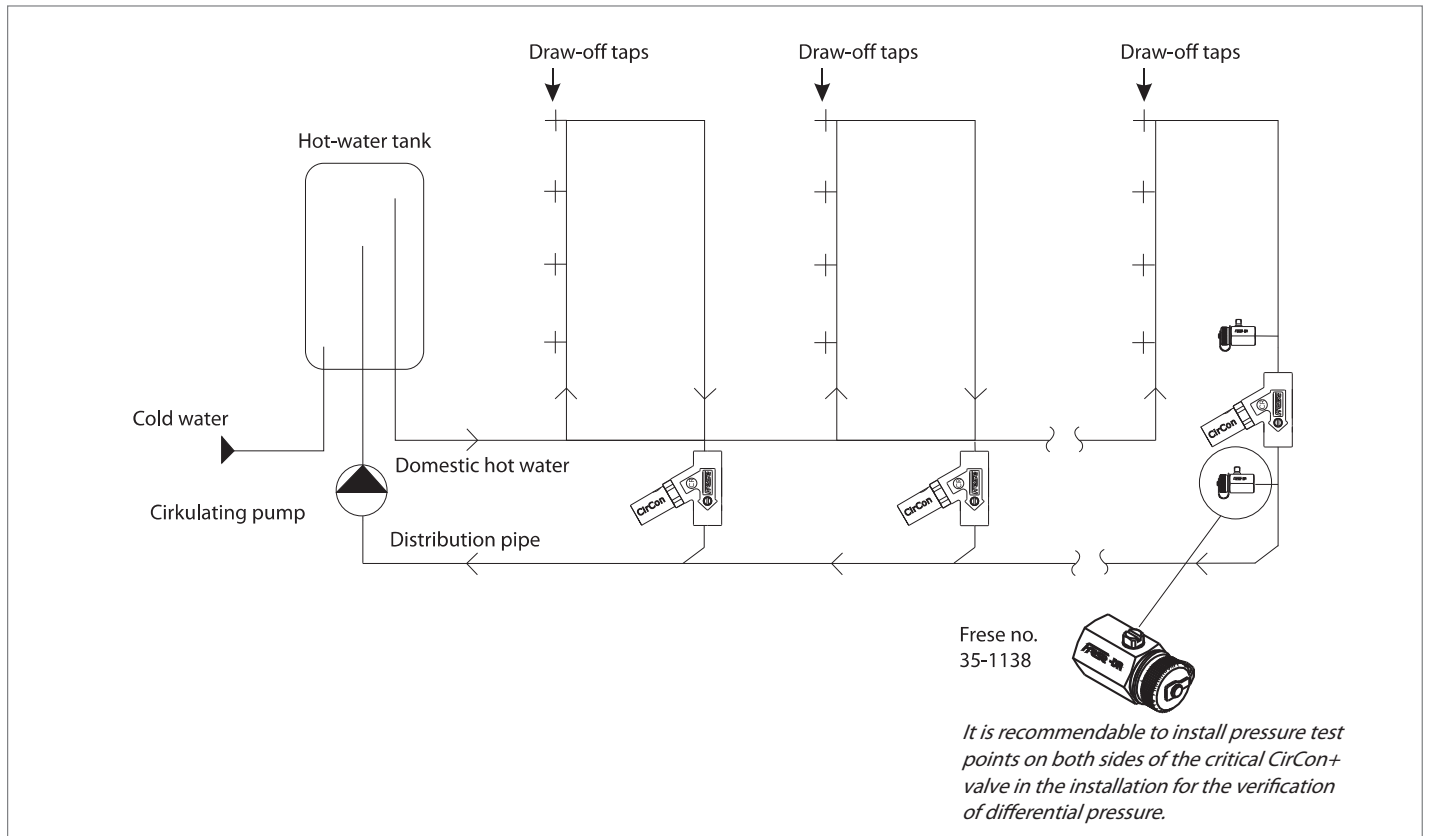

Dimensioning example - CirCon⁺

CirCon⁺ is dimensioned on the basis of the thermal loss in the circuit, in which it is located. An example of dimensioning CirCon⁺ and the overall quantity of water for the circulating pump is described in the following.

In an installation with 4 floors and basement a circulation line is dimensioned.

The following parameters should be known for the calculation of the flow rate.

Length of pipe: 30 meters. Total length of pipe controlled by CirCon⁺.

Thermal loss: 9 W/meter pipe. Thermal loss in an external 27 mm pipe with 30 mm insulation and a difference of 40°C between room temperature and temperature of the fluid.

Δ temperature differential: 5°C. Temperature in hot-water tank 55°C. CirCon⁺ was set to 50°C on the scale. The flow rate of CirCon⁺ can be found from the following formula:

$$Q = \frac{(30\text{m} \times 9\text{W/m}) \times 0,86}{5^\circ\text{C}} = 46 \text{ l/h}$$

So, the total quantity of water from 3 delivery pipes to the circulating pump is approx. 138 l/h (3 x 46 l/h).

The Kv-value of CirCon⁺ at 46 l/h and a differential pressure of 10 kPa across the valve can be found from the following formula:

$$K_v = \frac{Q}{\sqrt{\Delta p}} = \left(\frac{46}{\sqrt{10}} \right) / 100 = 0.15$$

CirCon⁺/TemCon⁺ - Thermostatic Valves for Domestic Water

Technical data - CirCon⁺

Materials:	DZR Brass, CW602N
Valve body:	EPDM
O-rings:	Stainless steel
Springs:	Wax
Element:	POM, ABS, PC
Plastic parts:	Tin/Nickel
Surface coating:	37°C - 65°C
Temperature range:	+/- 2°C < 100 kPa Dp
Accuracy:	10°C (Xp = 10K)
P-band:	1.10 (m ³ /l)
Max. Kv-value:	3 - 10 kPa
Recommended differential pressure:	100 kPa
Max. differential pressure:	PN10
Max. static pressure:	PN16
Pressure range:	

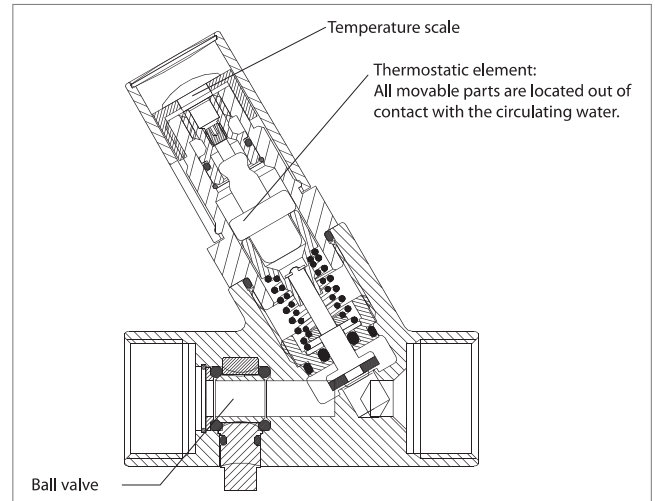

CirCon⁺ DN20 fem./fem. with ball valve

Product programme - CirCon⁺

Dimension	Frese no.	Weight [kg]	L x B x H
DN15 fem./fem.	47-2800	0.5	63/32/96
DN20 fem./fem.	47-2801	0.5	63/32/96
DN20 fem./fem. with ball valve	47-2802	0.6	79/37/96
DN20 male/male with ball valve	47-2803	0.6	79/37/96
Ø12 Cu/Pex with ball valve	47-2809	0.8	139/37/96
Ø15 Cu/Pex with ball valve	47-2810	0.8	139/37/96
Ø18 Cu/Pex with ball valve	47-2811	0.9	155/37/96
Ø22 Cu/Pex with ball valve	47-2812	0.9	155/37/96
Ø15 Press with ball valve	47-2815	0.7	117/37/96
Ø 18 Press with ball valve	47-2816	0.7	117/37/96
Ø22 Press with ball valve	47-2817	0.8	120/37/96

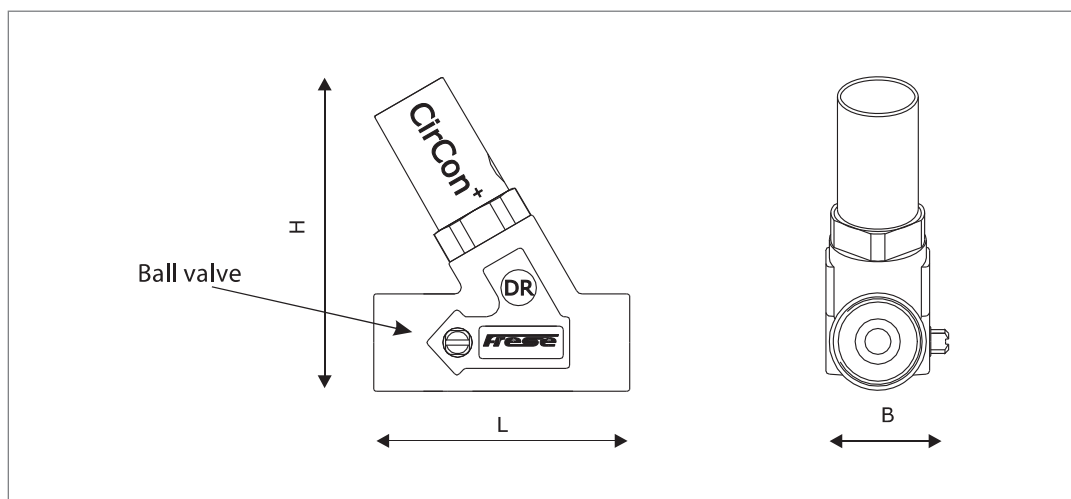

All CirCon+ valves have the approval of the Danish VA-Authorities.



CirCon⁺/TemCon⁺ - Thermostatic Valves for Domestic Water

TemCon⁺ - Control at two operating temperatures

TemCon⁺ was designed to control at two sets of temperatures, i.e.:

Normal operating temperature:

Normal operation occurs at temperatures from approx. 50°C to 60°C. That is economic operation at low precise flow rates, which ensures a high level of comfort at all draw-off taps and exact temperature in all circuits.

That is the most frequently applied operating range of the valve.

High operating temperature:

High operating temperature is used at intervals for the pasteurization of domestic water at 70°C to 80°C.



TemCon⁺ fem./fem. valves with scale by-pass and actuator by-pass respectively both of them with built in isolation ball valve.



TemCon⁺

The plastic cap is dismantled by means of a screwdriver that fits into the slot in the cap. Hereinafter the manually operated by-pass can be set steplessly to a Kv-value between 0.0 and 0.3.



Frese no. 47-2865: TemCon⁺ with press-couplings, and Frese no. 47-2867: TemCon⁺ with Cu-couplings. Ready for installation!

CirCon⁺/TemCon⁺ - Thermostatic Valves for Domestic Water

Application Example - TemCon⁺ Actuator operated by-pass

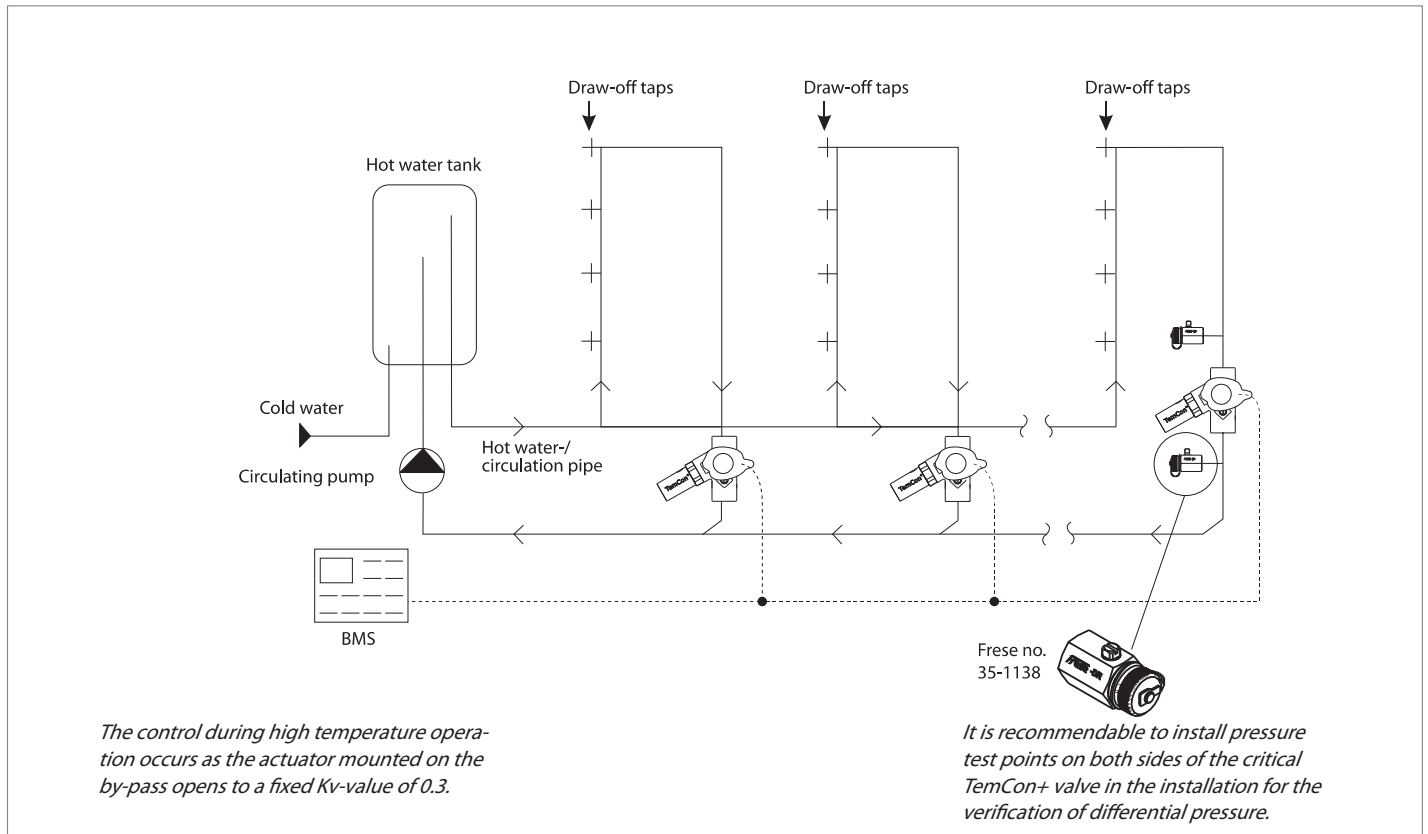

Dimensioning example - Acutaor operated by-pass

During normal operation:

During normal operation TemCon⁺ with actuator operated by-pass is dimensioned in the same way as thermal control (CirCon⁺ - see page 3).

High temperature operation:

The automatic heater or the BMS opens the by-pass to a fixed Kv-value of 0.3. In this example a sufficient quantity of water is ensured to compensate for the thermal loss in the pipe.

In an installation with 4 floors and basement a circulation line is dimensioned.

Length of pipe: 30 meters.

Total length of pipe controlled by TemCon⁺.

Thermal loss (high temperature operation):

14 W/meter pipe.

Thermal loss in an external 27 mm pipe with 30 mm insulation (laminated Rockwool) and a difference of 60°C between room temperature and pasteurization temperature.

Δ temperature differential: 8°C.

Between a temperature of 80°C in the hot-water tank and a temperature of 72°C after TemCon⁺.

The flow rate Q of the TemCon⁺ valve can be found from the following formula:

$$Q = \frac{(30\text{m} \times 14\text{w/m}) \times 0,86}{8^\circ\text{C}} = 45 \text{ l/h}$$

The minimum differential pressure of the TemCon+ valve at a constant Kv-value of 0.3 can be found from the following formula:

$$\Delta p = \left(\frac{45}{0,3 \times 1000} \right)^2 = 2 \text{ kPa}$$

Hydraulic balance

The application of a circulating pump with proportional control of the pump pressure is recommendable if a fixed Kv-value of 0.3 is too much for the installation so that the hydraulic balance is upset. The pump compensates for increased flow by increasing the differential pressure.

CirCon⁺/TemCon⁺ - Thermostatic Valves for Domestic Water

Dimensioning example - adjustable by-pass

High temperature operation:

On the basis of the dimensioning example for actuator controlled by-pass and high temperature operation the flow rate is found from the formula:

$$Q = \frac{30 \times 14 \times 0,86}{8} = 45 \text{ l/h}$$

The differential pressure across TemCon⁺ at the given location in the system should be known in order to find the value of the adjustable by-pass.

Here we use 35 kPa across the valve. The value can be found from the formula:

$$K_v = \frac{Q}{\sqrt{\Delta p}} = \left(\frac{0,045}{\sqrt{0,35}} \right) = 0,08$$

Consequently, the by-pass should be opened to min. 0.08 to ensure a temperature of 72°C after the valve.

Normal operation:

During normal operation it is recommendable to close the adjustable by-pass to gain all the benefits of the thermal control of the TemCon+ valve.

Technical data - TemCon⁺

Materials:	
Valve body:	DZR Brass, CW602N
O-rings:	EPDM
Springs:	Stainless steel
Element:	Wax
Plastic parts:	POM, ABS, PC
By-pass:	Stainless steel
Surface coating:	Tin/Nickel
Temperature rating:	37°C - 65°C
Accuracy:	+/- 2°C < 100 kPa Dp
P-band:	10°C (Xp = 10K)
Max. Kv-value:	1.10 (m ³ /l)
Recommended differential pressure:	3 - 10 kPa
Max. differential pressure:	100 kPa
Max. static pressure:	PN10
Max. temperature:	100°C
Pressure rating:	PN10

Actuator controlled by-pass:

Kv-value, open by pass:	0.3 (m ³ /h)
Running time:	180 sec. from closed to fully open
Power consumption:	1,8W
Supply voltage:	24V DC/AC or 230 V AC

Wiring diagram

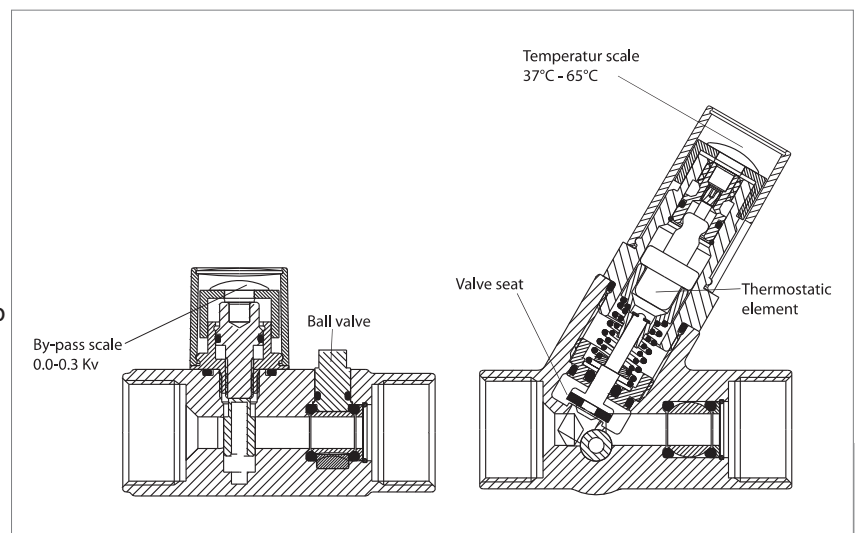
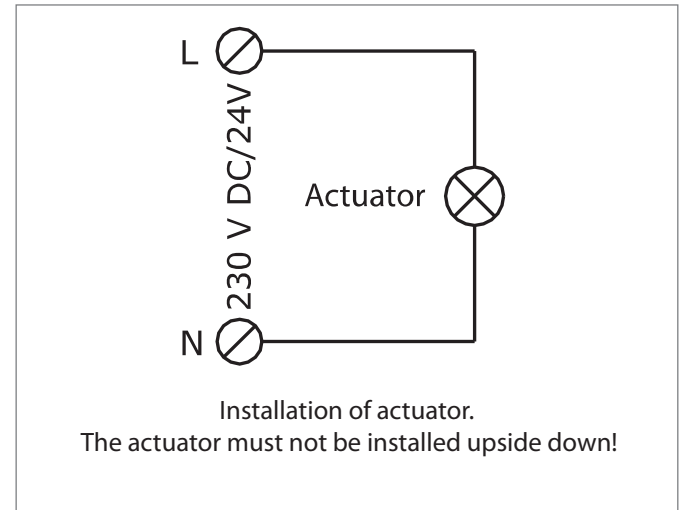

Section drawing of TemCon⁺ DN20 fem./fem. with ball valve

Product programme - TemCon⁺

Dimension	Frese no.	Weight [kg]	L x B x H
DN15 fem./fem.	47-2850	0.6	63/58/99
DN20 fem./fem.	47-2851	0.5	63/58/99
DN20 fem./fem. with ball valve	47-2852	0.6	79/58/99
DN20 male/male with ball valve	47-2853	0.6	79/58/99
Ø12 Cu/Pex with ball valve	47-2859	0.8	139/58/99
Ø15 Cu/Pex with ball valve	47-2860	0.8	139/58/99
Ø18 Cu/Pex with ball valve	47-2861	1.0	155/58/99
Ø22 Cu/Pex with ball valve	47-2862	0.9	155/58/99
Ø15 Press with ball valve	47-2867	0.8	117/58/99
Ø 18 Press with ball valve	47-2868	0.8	117/58/99
Ø22 Press with ball valve	47-2869	0.8	120/58/99
Accessories:			
Universal insulation	47-9001	0.03	165/73/118
Acutatorkit 230V	47-2866	0.15	79/86/120
Actuatorkit 24V	47-2865	0.15	79/86/120
Insulation for valve with actuator	47-9002	0.01	165/106/125

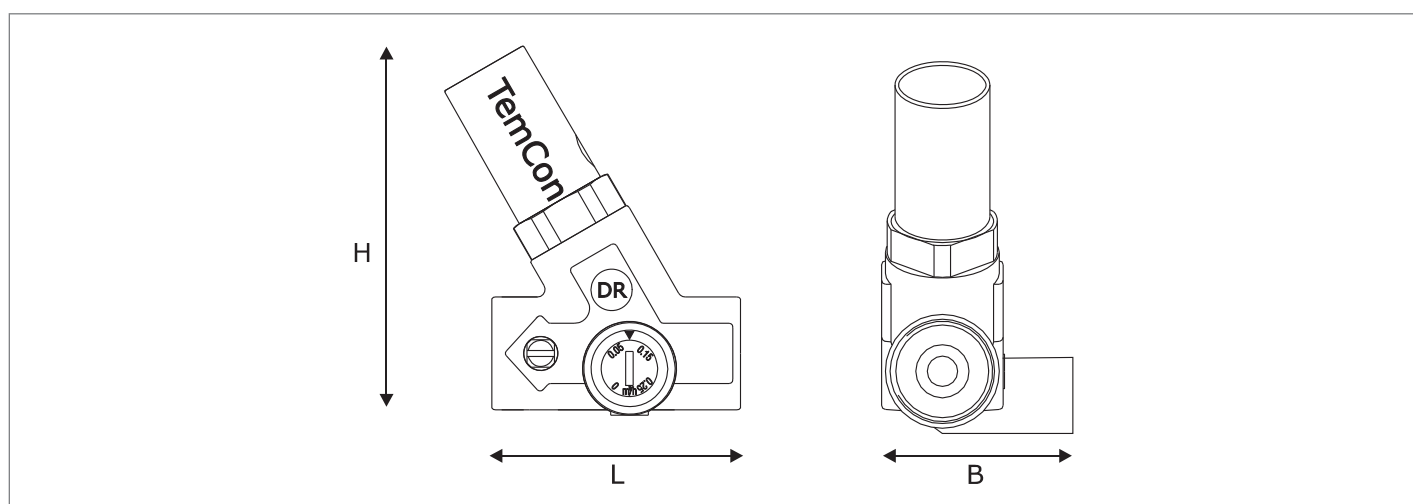

Frese A/S assumes no responsibility for errors, if any, in catalogues, brochures, and other printed matter. Frese A/S reserves the right to modify its products without prior notice, including already ordered products, if this does not alter existing specifications. All registered trademarks in this material are the property of Frese A/S. All rights reserved.

Frese A/S
 Sorøvej 8
 DK- 4200 Slagelse
 Tel: +45 58 56 00 00
 Fax: +45 58 56 00 91
 frese@frese.dk

