

Frese OPTIMA Compact - Pressure independent balancing & control valve

Application

Frese OPTIMA Compact pressure independent balancing & control valve (PIBCV) is used in heating and cooling systems in applications with Fan Coil Units, Chilled Beams or other terminal unit applications.

Frese OPTIMA Compact provides modulating control with full authority regardless of any fluctuations in the differential pressure of the system.

Frese OPTIMA Compact combines an externally adjustable automatic balancing valve, a differential pressure control valve and a full authority modulating control valve.

Frese OPTIMA Compact makes it simple to achieve 100% control of the water flow in the building, while creating high comfort and energy savings at the same time. An additional benefit is that no balancing is required if further stages are added to the system, or if the dimensioned capacity is changed.

Energy saving due to optimal control, lower flow and pump pressure. Maximized ΔT due to faster response and increased system stability.

Benefits

Design

- Less time to define the necessary equipment for a hydraulic balanced system (only flow data are required)
- No need to calculate valve authority. Always one.
- Flexibility if the system is modified after the initial installation

Installation

- No further regulating valves required in the distribution pipework when Frese OPTIMA Compact is installed at terminals.
- Total number of valves minimized due to the 3-in-1 design
- Minimized commissioning time due to automatic balancing of the system
- No minimum straight pipe lengths required before or after the valve.

Operation

- High comfort for the end-users due to high precision temperature control
- Longer life due to less movements of the actuator



Features

- The presetting function has no impact on the stroke; Full stroke modulation at all times, regardless the preset flow.
- The constant differential pressure across the modulating control component guarantees 100% authority.
- Automatic balancing eliminates overflows, regardless of fluctuating pressure conditions in the system.
- Thermal actuator On/Off or 0....10V, normally closed.
- Electro mechanical actuator 0-10 V and 3 point control, normally closed
- Differential pressure operating range up to 400 kPa
- High flows with minimal required differential pressure due to advanced design of the valve
- Small dimensions due to compact housing
- Higher presetting precision due to stepless analogue scale

Frese OPTIMA Compact - Pressure independent balancing & control valve

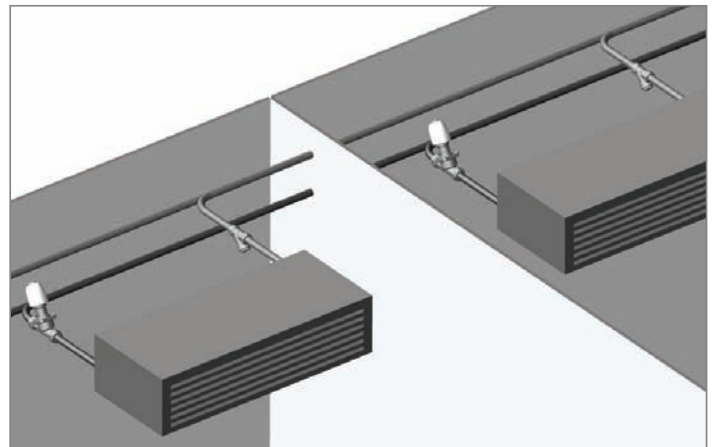
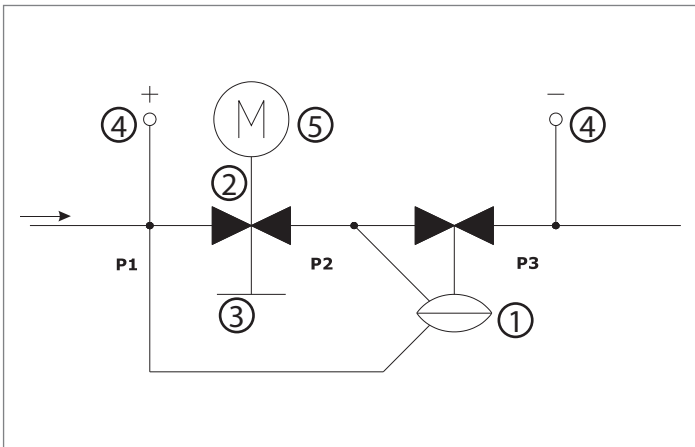

Design

The design of Frese OPTIMA Compact combines high performance with small size and compact construction. The main components of the valve are:

- ① Differential pressure control
- ② Modulating control component
- ③ Presetting scale (not accessible when the actuator is mounted)
 - ⓐ Flow range: Low-High
 - ⓑ Stroke: 2,5mm-4,0mm-5,0mm
- ④ P/T Plugs (Optional)
- ⑤ Actuator

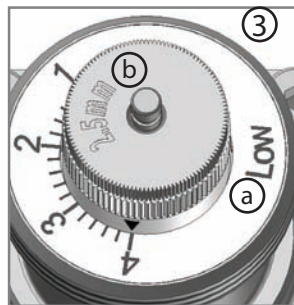

Function

Frese OPTIMA Compact can be flushed and commissioned before the actuator is installed.

The presetting of the dial is user-friendly requiring only a simple flow vs. presetting graph.

Once the flow is set, the actuator can be mounted and the valve ready to operate.

For lowest energy consumption, check the differential pressure at the index valve to set the pump at minimum speed.

Manual operation

Electro mechanical actuators

The actuator can be operated manually with the help of a 3mm hex key.

Note

If the operation is performed manually without disconnecting from the power, the supply must be disconnected and then reconnected, whereby the actuator will start the calibration process and correctly adjust itself.

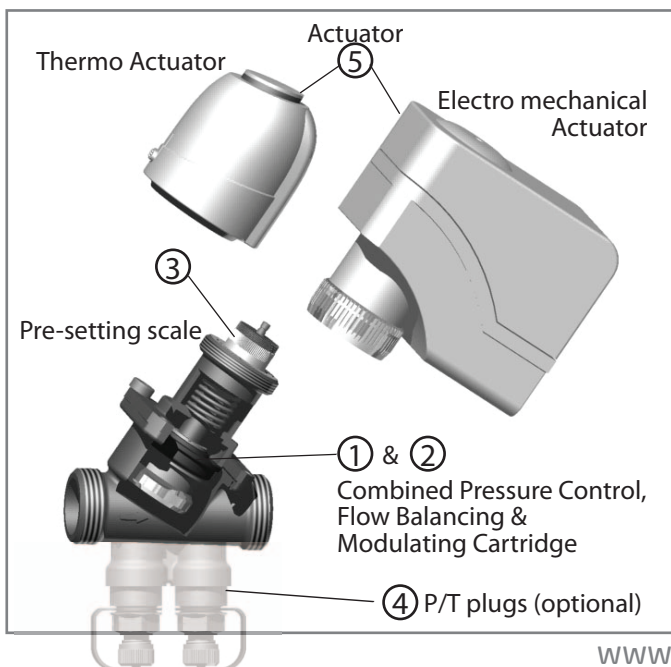

Frese OPTIMA Compact - Pressure independent balancing & control valve

Operation principle

The innovative design of Frese OPTIMA Compact features a modulating control component that retains 100% authority at all times.

With the Frese OPTIMA Compact, there are two independent movements for the presetting and the modulating function. During presetting, the inlet area moves radially without interfering with the length of the stroke. During modulating, the inlet area moves axial taking advantage of the full stroke.

Whilst the control component provides proportional modulation irrespective of the preset flow, the automatic balancing guarantees that the flow will never exceed the maximum preset flow.

Regardless of pressure fluctuations in the system, the maximum flow is kept constant up to a maximum differential pressure of 400kPa.

Flow rate vs. Differential Pressure

(Preset flow: 300 l/h, 150 l/h)

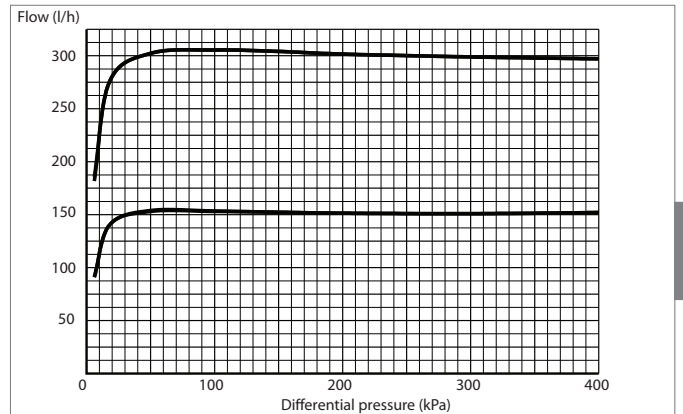

Flow rate vs. Voltage

(Preset flow: 300 l/h, 150 l/h)

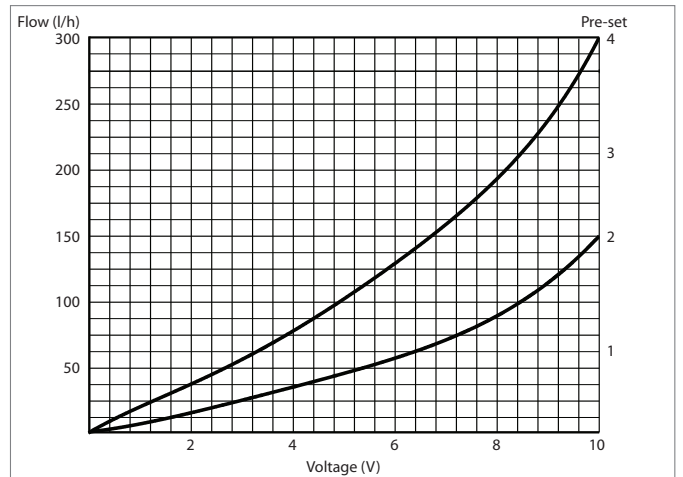

Flow rate vs. Differential Pressure

(Voltage: 10V, 8V, 5V)

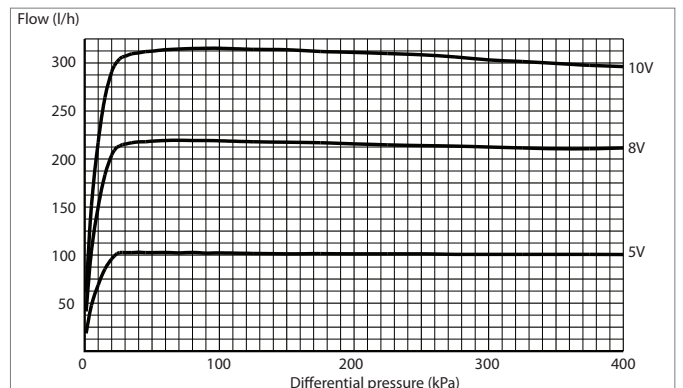

Frese OPTIMA Compact - Pressure independent balancing & control valve

Technical data

Valve

- Valve housing and flow setting:** DZR Brass, CW602N
- DP controller:** PPS 40% glass
- Spring:** Stainless steel
- Diaphragm:** HNBR
- O-rings:** EPDM
- Pressure class:** PN25
- Max. differential pressure:** 400 kPa
- Medium temperature range:** 0°C to 120°C

The pipe system shall be properly ventilated to avoid risk of air pockets. Glycolic mixtures up to 50% are applicable (both ethylene and propylene).
Frese A/S can accept no responsibility if another actuator is used instead of the Frese actuator

Technical data

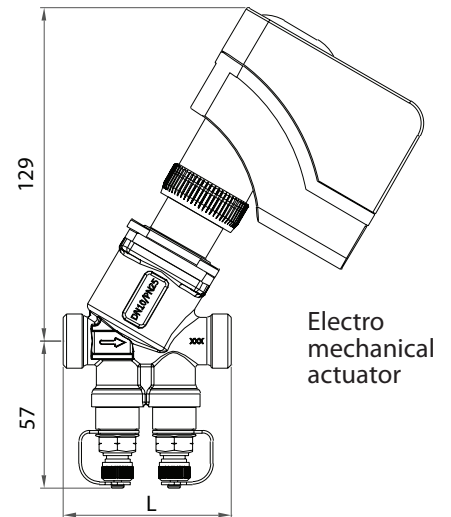
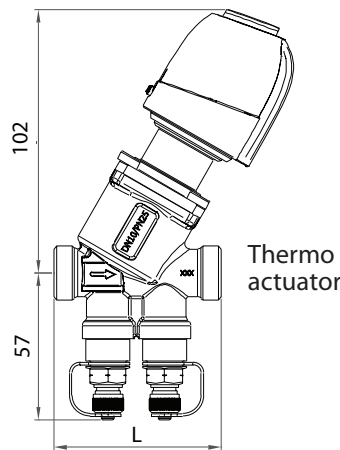
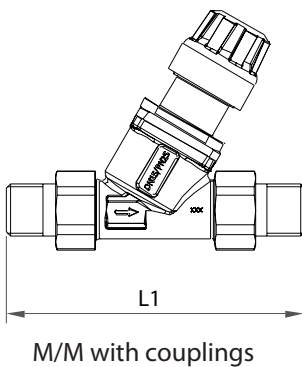

5

Dimension & Weight

Valve Size		DN10		DN15		DN20	
Type	Thread	M/M	F/F	M/M	F/F	M/M	F/F
Length	L	65	-	65	75	70	79
	L1	114	-	122	-	131	-
Weight kg	Basic	0.36	-	0.38	0.42	0.40	0.45
	P/T plugs	0.45	-	0.47	0.52	0.50	0.54

Flow

Type Cartridge		Low		High		
Stroke	mm	2.5	5.0	2.5	4.0	5.0
Flow	l/h	30 - 182	66 - 360	97 - 544	157 - 962	219 - 1256
	l/s	0.008 - 0.051	0.018 - 0.100	0.027 - 0.151	0.044 - 0.267	0.061 - 0.349
	gpm	0.13 - 0.80	0.29 - 1.59	0.43 - 2.40	0.69 - 4.24	0.97 - 5.53

Frese OPTIMA Compact - Pressure independent balancing & control valve

Technical data actuators

Characteristics:	Thermo actuators, normally closed
Protection class:	IP 54 to EN 60529
Frequency:	50/60 Hz
Control signal:	0-10V DC or On/Off
Actuating force:	100 N
Stroke:	2.5mm or 4.0 mm
Running time:	120 s 0-10V/180 s On/Off
Ambient operating conditions:	0°C to 60°C
Cable length:	1.0 m
Weight:	100 g



On/Off actuator 2.5 & 4.0 mm stroke, 24V AC-DC / On/Off 180s	48-5520
On/Off actuator 2.5 & 4.0 mm stroke 230V / On/Off 180s	48-5521
Modulating actuator 4.0 mm stroke 24V AC-DC / 0-10V DC 120 s	48-5522
Modulating actuator 2.5 mm stroke 24V AC-DC / 0-10V DC 120 s	48-5523

Characteristics:	Electrical, modulating, normally closed
Protection class:	IP 40 to EN 60529
Frequency:	50/60 Hz
Control signal:	0-10V DC or 3 position
Actuating force:	100 N
Stroke:	5.0 mm
Running time:	75 s 0-10V / 150 s 3-pos
Ambient operating conditions:	+1°C to 50°C
Manual operation:	3 mm Hexagonal key
Cable length:	1.5 m
Weight:	350 g

Modulating actuator 5.0 mm stroke 24V AC-DC / 0-10V DC / 75 s	53-1056
Modulating actuator 5.0 mm stroke 24 V AC / 3 pos / 150 s	53-1057
Modulating actuator 5.0 mm stroke 230 V AC / 3 pos. / 150 s	53-1058

5

Product program

Size	Cartridge	Flow l/h				
			M/M	M/M PT plugs	F/F	F/F PT plugs
DN10	Low 2.5 mm	30-182	53-1300	53-1320	-	-
	Low 5.0 mm	66-360	53-1309	53-1329	-	-
DN15	Low 2.5 mm	30-182	53-1302	53-1322	53-1342	53-1362
	Low 5.0 mm	66-360	53-1310	53-1330	53-1350	53-1370
	High 2.5 mm	97-544	53-1304	53-1324	53-1344	53-1364
DN20	High 2.5 mm	97-544	53-1312	53-1332	53-1352	53-1372
	High 4.0 mm	157-962	53-1307	53-1327	53-1347	53-1367
	High 5.0 mm	219-1256	53-1308	53-1328	53-1348	53-1368

Frese OPTIMA Compact - Pressure independent balancing & control valve

Actuator requirements

Dimension "X" in closed position
 2.5 mm stroke = 11.4mm
 4.0 mm stroke = 11.4mm
 5.0 mm stroke = 9.2 mm

Actuator minimum force: 100N

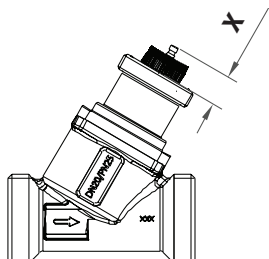

Couplings

Couplings 2 pcs, incl gasket

Material: DZR Brass, CW602N

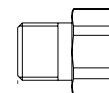

Size	
DN10	43-1330
DN15	43-2330
DN20	43-3330



Combination matrix: Frese OPTIMA Compact / Actuators

Frese OPTIMA Compact can be combined with both Thermo actuators and Electro mechanical actuators.

The design of the valve, combined with the Frese actuator, produces a perfect control characteristic that utilises the full control range of the system.

		Thermo Actuators				Electro mechanical Actuators		
		On/Off		0...10V		0...10V	3-Pos	
		24V	230V	2,5mm	4,0 mm	24V	24V	230V
	Type / OPTIMA COMPACT	Stroke	Flow l/h	Dimension				
	DN10 M/M LOW 2,5	2,5	30-182	DN10	●	●	●	
	DN10 M/M LOW 5,0	5,0	66-360	DN10				● ● ●
	DN15 M/M LOW 2,5	2,5	30-182	DN15	●	●	●	
	DN15 M/M LOW 5,0	5,0	66-360	DN15				● ● ●
	DN15 M/M HIGH 2,5	2,5	97-544	DN15	●	●	●	
	DN20 M/M HIGH 2,5	2,5	97-544	DN20	●	●	●	
	DN20 M/M HIGH 4,0	4,0	157-962	DN20	●	●		●
DN20 M/M HIGH 5,0	5,0	219-1256	DN20				● ● ●	
	Type / OPTIMA COMPACT	Stroke	Flow l/h	Dimension				
	DN15 F/F LOW 2,5	2,5	30-182	DN15	●	●	●	
	DN15 F/F LOW 5,0	5,0	66-360	DN15				● ● ●
	DN15 F/F HIGH 2,5	2,5	97-544	DN15	●	●	●	
	DN20 F/F HIGH 2,5	2,5	97-544	DN20	●	●	●	
	DN20 F/F HIGH 4,0	4,0	157-962	DN20	●	●		●
	DN20 F/F HIGH 5,0	5,0	219-1256	DN20				● ● ●

5

Frese OPTIMA Compact - Pressure independent balancing & control valve

Frese OPTIMA Compact Low 2,5 DN10/15

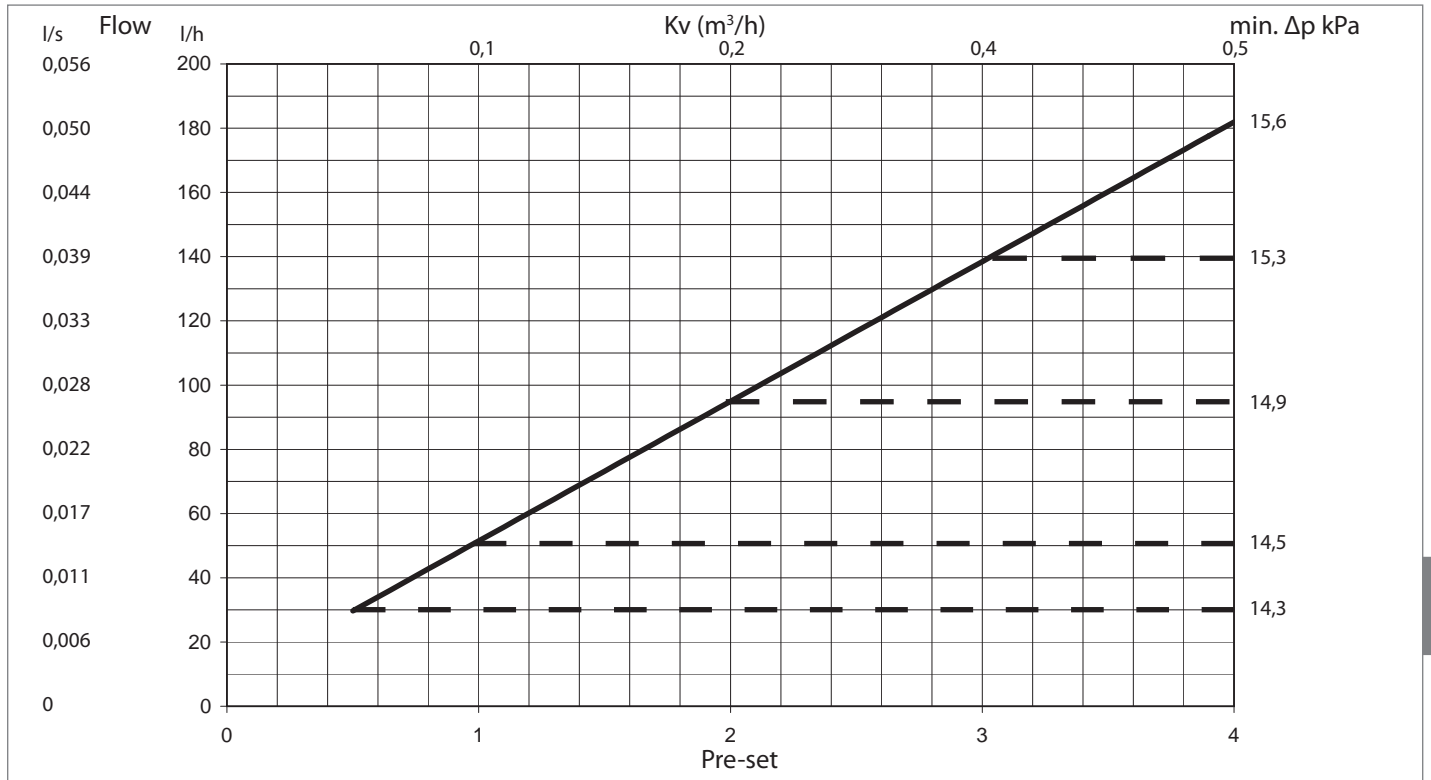

Frese OPTIMA Compact Low 5,0 DN10/15

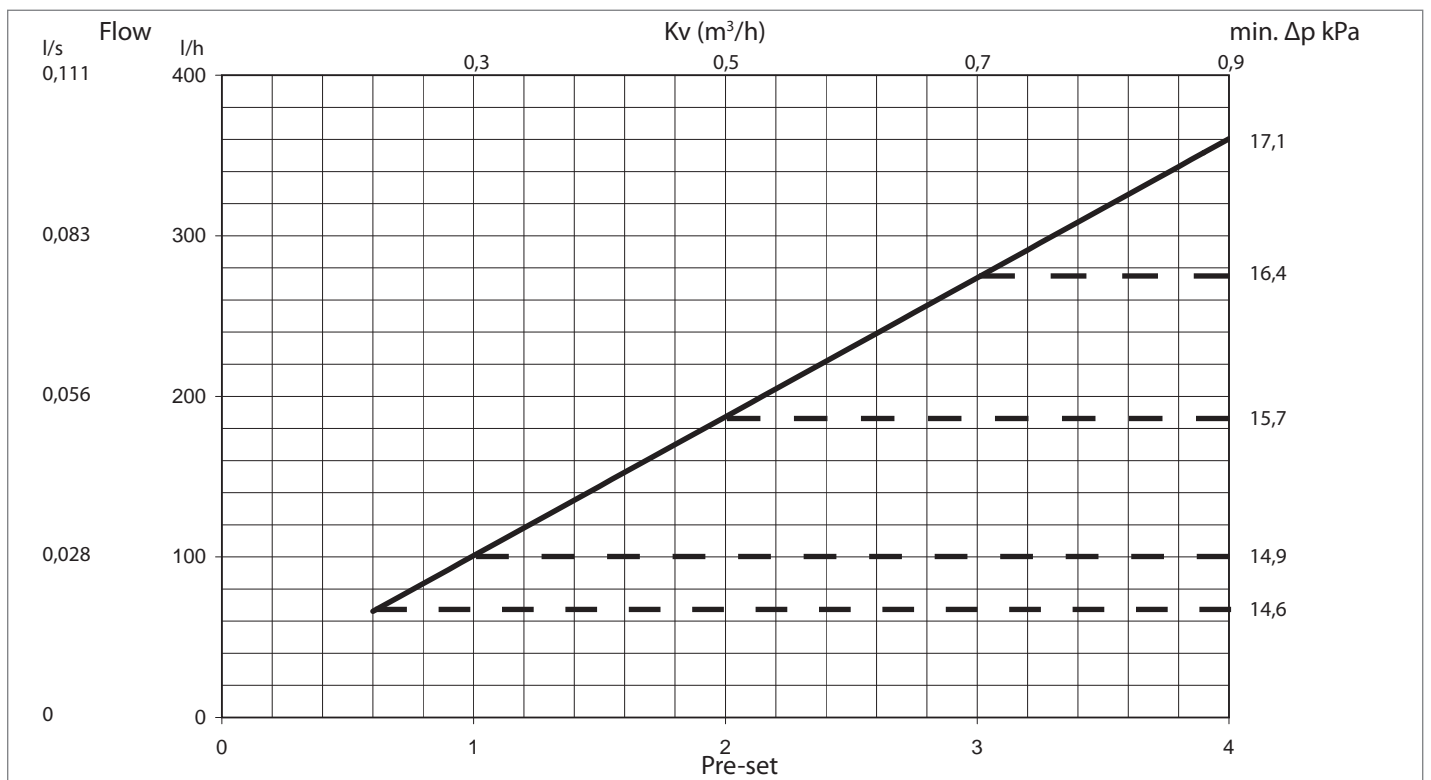

Frese OPTIMA Compact - Pressure independent balancing & control valve

Frese OPTIMA Compact High 2,5 DN15/20

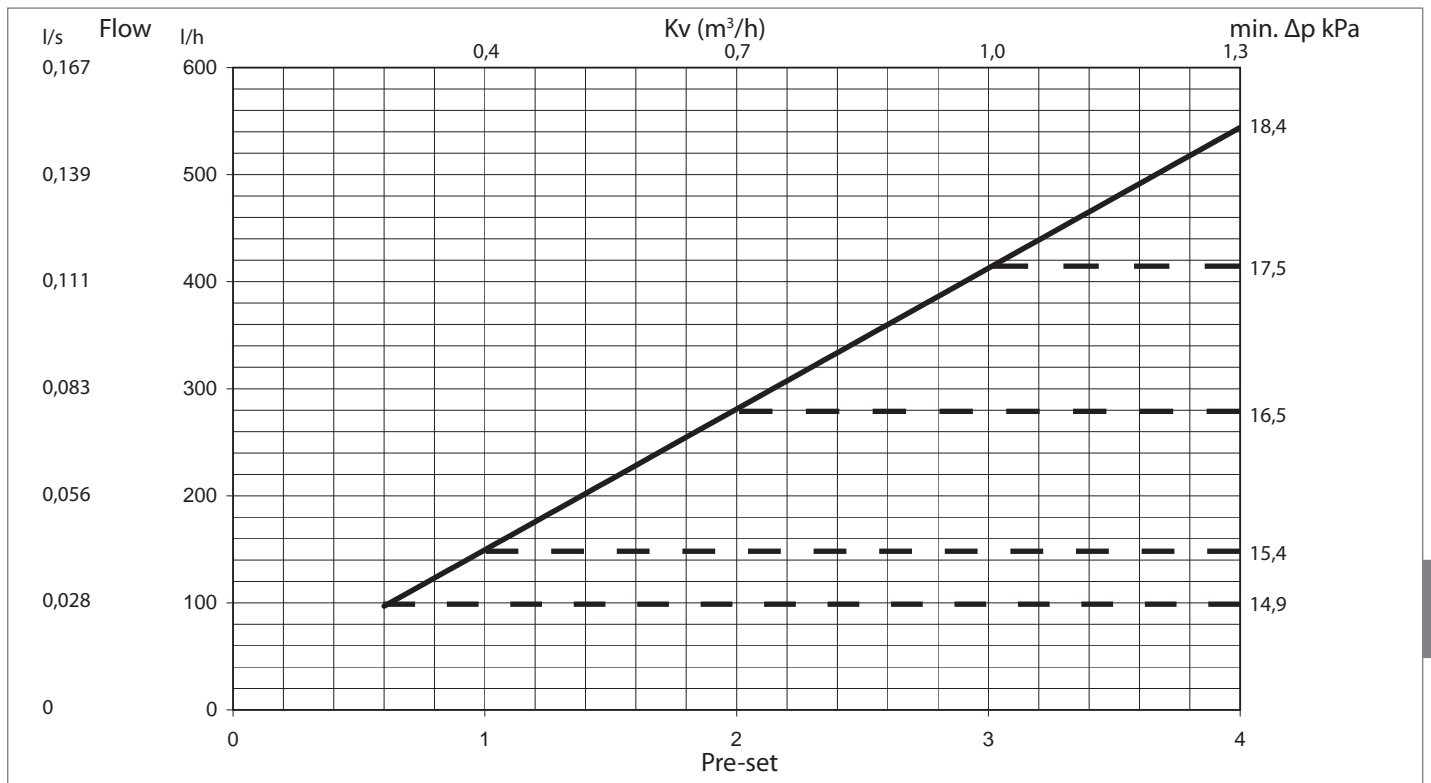

Frese OPTIMA Compact High 4,0 DN20

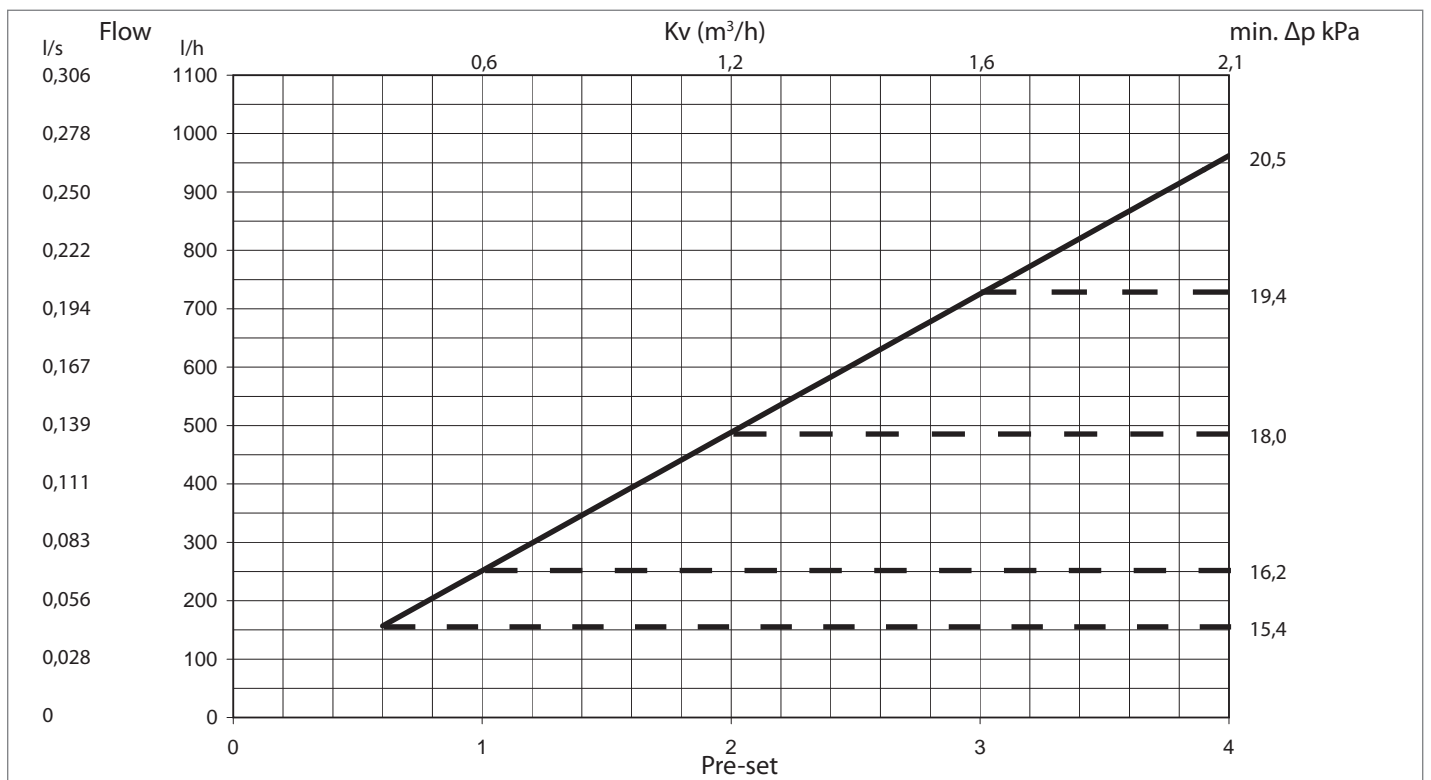

Frese OPTIMA Compact - Pressure independent balancing & control valve

Frese OPTIMA Compact High 5,0 DN20

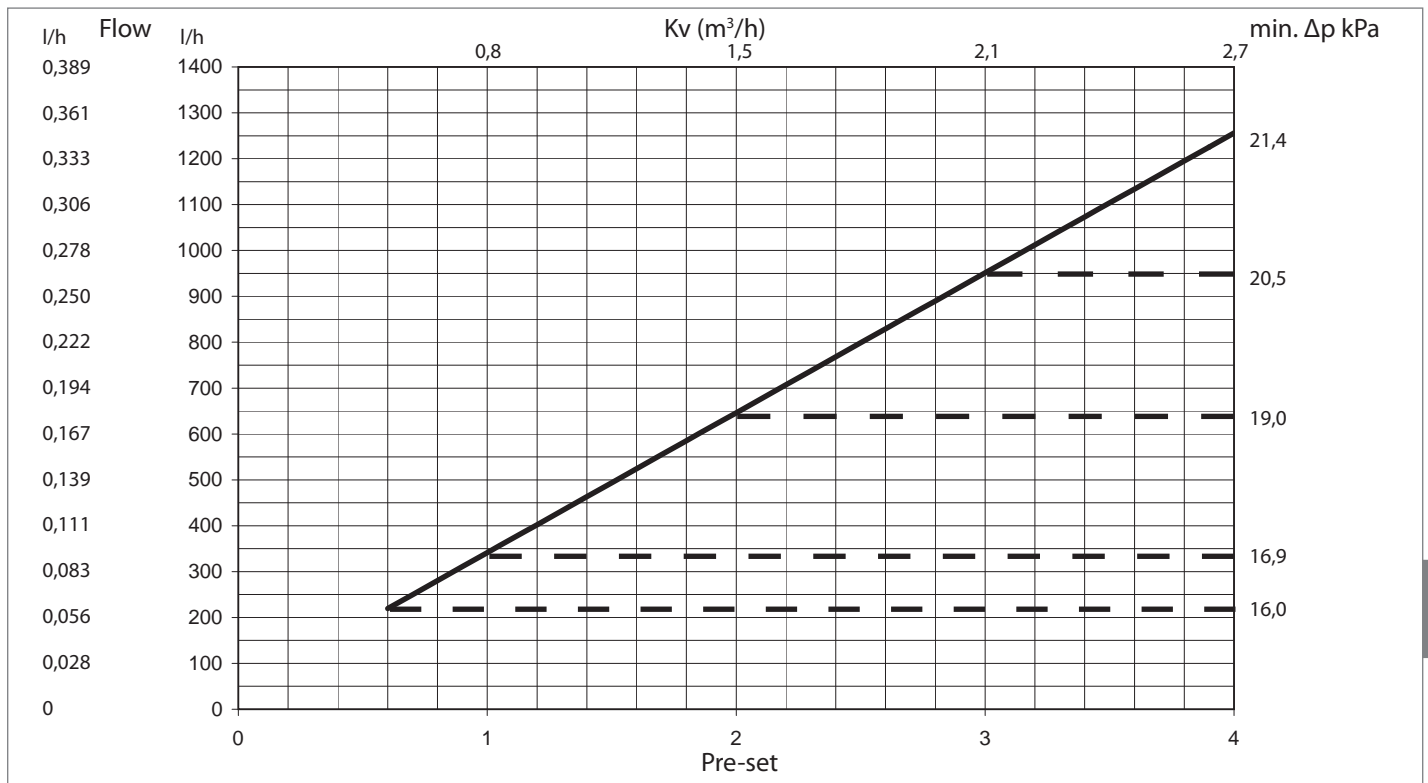

Text for technical specifications

- The length of the modulating stroke shall be independent of flow setting.
- The modulation and flow setting shall be one combined unit with a linear modulating motion and a rotational flow setting motion.
- The valve characterisation shall not be changed at different flow settings.
- The combined flow setting and modulating control unit shall be pressure independent.
- The The Pressure Independent Control Valve shall contain a combined flow setting, differential pressure control and modulating bonnet assembly.
- The valve housing shall be hot stamped DZR brass CW602N.
- The valve shall have a spring made of stainless steel, a Diaphragm made of HNBR and O-rings made of EPDM.
- The valve housing shall be PN25 rated and suitable for 120°C.
- The valve shall have an external thread ISO 228 or internal ISO 7/1.
- The valve shall have a maximum operating differential pressure of 400 kPa (4 Bar)
- The valve shall have an external adjustable analogue step less presetting scale from minimum to maximum flow.
- P/T plugs shall be available as an option.
- The valve shall have a leakage rate at maximum 0,01% of max rated volumetric flow and comply to EN1349 Class IV.

Frese OPTIMA Compact - Pressure independent balancing & control valve

Setting and Flow

OPTIMA Compact Low 2,5 DN10/15			
Pre-set	Flow l/h	Flow l/s	Flow gpm
0,5	30	0,008	0,13
0,6	34	0,009	0,15
0,8	43	0,012	0,19
1,0	51	0,014	0,23
1,2	60	0,017	0,26
1,4	69	0,019	0,30
1,6	78	0,022	0,34
1,8	86	0,024	0,38
2,0	95	0,026	0,42
2,2	104	0,029	0,46
2,4	112	0,031	0,49
2,6	121	0,034	0,53
2,8	130	0,036	0,57
3,0	138	0,038	0,61
3,2	147	0,041	0,65
3,4	156	0,043	0,69
3,6	165	0,046	0,72
3,8	173	0,048	0,76
4,0	182	0,051	0,80

OPTIMA Compact Low 5,0 DN10/15		
Flow l/h	Flow l/s	Flow gpm
66	0,018	0,29
83	0,023	0,37
101	0,028	0,44
118	0,033	0,52
135	0,038	0,60
153	0,042	0,67
170	0,047	0,75
187	0,052	0,82
205	0,057	0,90
222	0,062	0,98
239	0,066	1,05
257	0,071	1,13
274	0,076	1,21
291	0,081	1,28
308	0,086	1,36
326	0,090	1,43
343	0,095	1,51
360	0,100	1,59

OPTIMA Compact High 2,5 DN15/20			
Pre-set	Flow l/h	Flow l/s	Flow gpm
0,6	97	0,027	0,43
0,8	123	0,034	0,54
1,0	149	0,042	0,66
1,2	176	0,049	0,77
1,4	202	0,056	0,89
1,6	228	0,063	1,01
1,8	255	0,071	1,12
2,0	281	0,078	1,24
2,2	307	0,085	1,35
2,4	334	0,093	1,47
2,6	360	0,100	1,58
2,8	386	0,107	1,70
3,0	413	0,115	1,82
3,2	439	0,122	1,93
3,4	465	0,129	2,05
3,6	491	0,137	2,16
3,8	518	0,144	2,28
4,0	544	0,151	2,40

OPTIMA Compact High 4,0 DN20		
Flow l/h	Flow l/s	Flow gpm
157	0,044	0,69
204	0,057	0,90
252	0,070	1,11
299	0,083	1,32
346	0,096	1,52
394	0,109	1,73
441	0,123	1,94
488	0,136	2,15
536	0,149	2,36
583	0,162	2,57
631	0,175	2,78
678	0,188	2,98
725	0,201	3,19
773	0,215	3,40
820	0,228	3,61
867	0,241	3,82
915	0,254	4,03
962	0,267	4,24

OPTIMA Compact High 5,0 DN20		
Flow l/h	Flow l/s	Flow gpm
219	0,061	0,97
280	0,078	1,23
341	0,095	1,50
402	0,112	1,77
463	0,129	2,04
524	0,146	2,31
585	0,163	2,58
646	0,180	2,84
707	0,196	3,11
768	0,213	3,38
829	0,230	3,65
890	0,247	3,92
951	0,264	4,19
1012	0,281	4,46
1073	0,298	4,72
1134	0,315	4,99
1195	0,332	5,26
1256	0,349	5,53

