

Nash Products & Services for Energy & Water Savings



Gardner Denver Nash makes it easy to upgrade your vacuum installation to the latest liquid ring technology and reduce your energy or water use.

Existing Model	New Model	Seal Water Rate (GPM)		Estimated Annual Water Cost Savings
		Existing	New	
CL 402	Vectra XL 80	12	5	\$10,000
CL 702	Vectra XL 130	20	6	\$20,000
CL 1002	Vectra XL 250	20	10	\$14,000
Vectra XL130 Investment → 8 Month Payback				

Assumed:
 \$3/1,000 gal H₂O
 8,000 operating hours/year
 Once thru operation

Nash Vectra XL pumps have been efficient and reliable work horses since their introduction nine years ago. Now, with the adapter kits, it is easy to replace your aging CL series pumps and reduce your operating costs. The upgrades also make plants more environmentally friendly.



Vectra/Adapter Kit Benefits:

- 50% or greater water savings
- Improved pumping to higher vacuum levels
- Easy to install, no process piping changes
- Uses existing base motor and drive
- Potential payback of less than one year due to lower operating costs
- Readily available inventory
- Available in both cast iron and stainless steel

Additional Vectra Benefits:

- Mechanical seal options
- Deeper vacuum capability
- Wider operating speed range
- Reduced maintenance costs

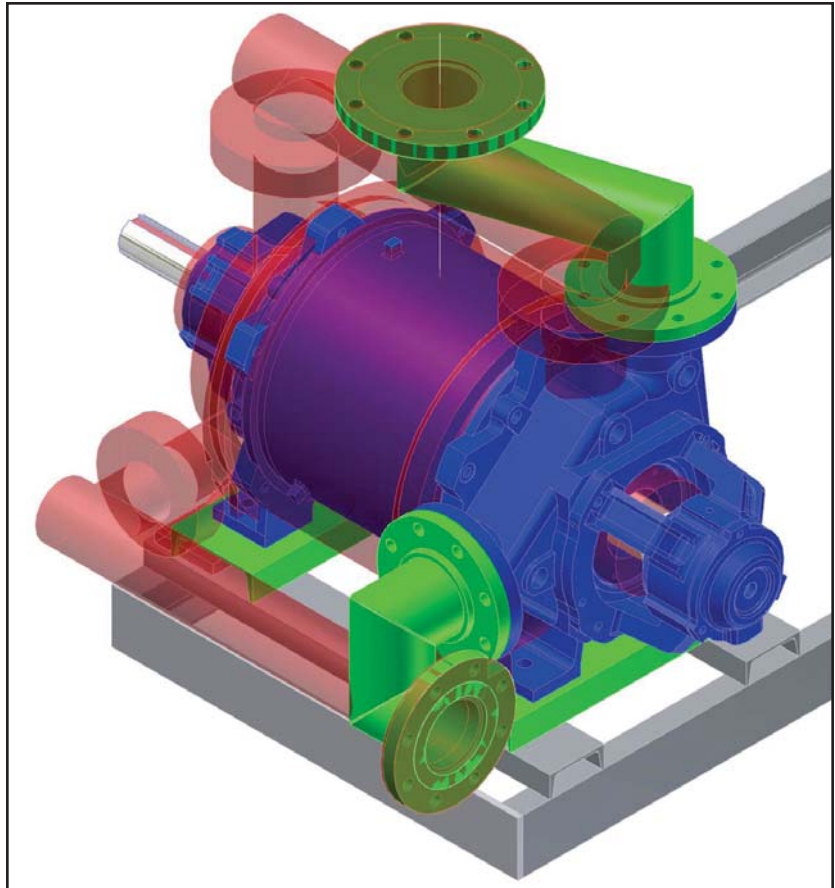

Process Piping Connections are Unchanged

Vectra (blue) superimposed over the
CL (red) it will replace.
The adapters are shown in green.

NASH

A Div. of Gardner Denver

9 Trefoil Drive
Trumbull, CT 06611 U.S.A.
tel: 800 553 NASH
+ 203 459 3900
fax: + 203 459 3988
nash@gardnerdenver.com
www.GDNash.com

