

## Dimension for installation:

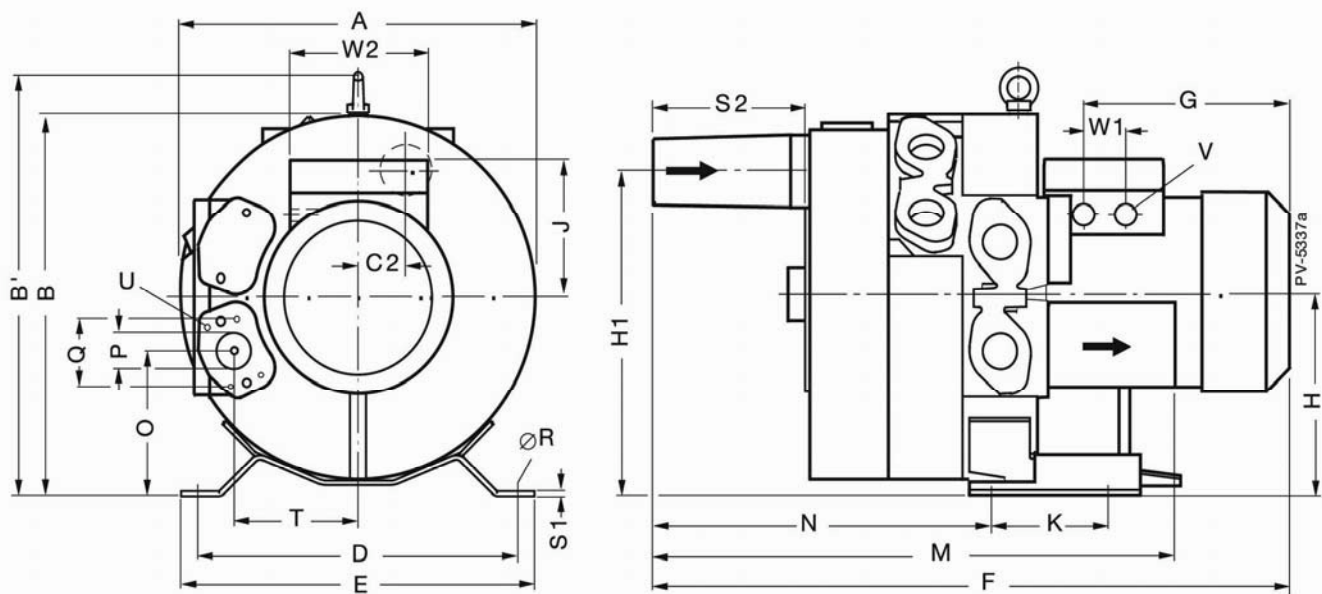

## Dimension data:

MODEL	curve No	A	B	B'	C2	D	E	F	G	H	H1	J	M	N
4RB 630 H67	B282/283	442	457	495	63	371	406	710	267	236	389	167	538	339
MODEL	curve No	O	P	Q	R	S1	S2	T	U	V	W1	W2		
4RB 630 H67	B282/283	172	G1¼	64	14	5	146	153	M6 x 17	M32 x 1.5	42	140		



# GREENCO 4RB SERIES HIGH PRESSURE RING BLOWER

## 4RB 630 SERIES

### Vacuum-compressor performance diagram

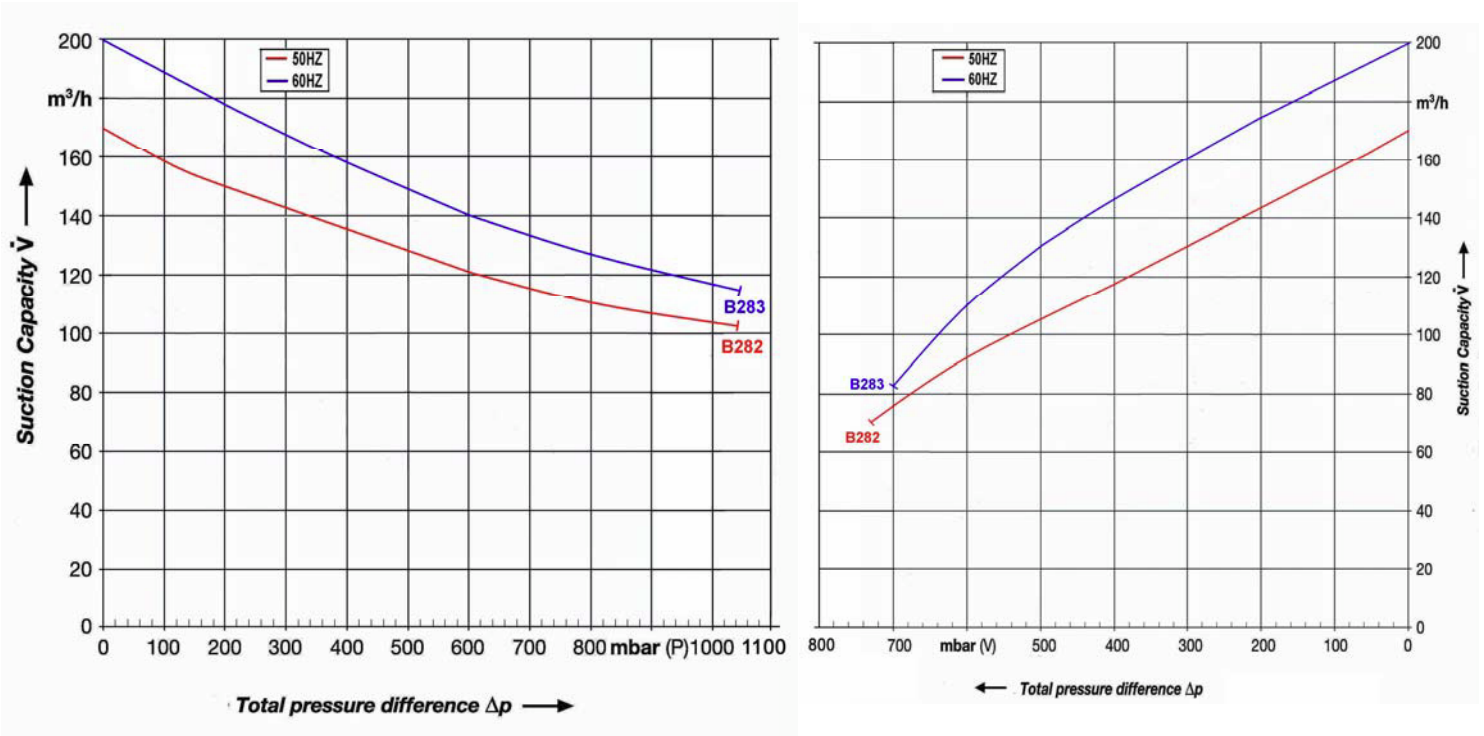

### Feature:

- Oil Free
- Maintenance free
- Operate quietly
- Cooler running outboard bearing increase service life
- Easy to install, close-couple construction
- Compact light weight design
- Handles vacuum and or pressure applications
- Ideal alternative to standard rotary vane pump and PD/rotary lobe blowers

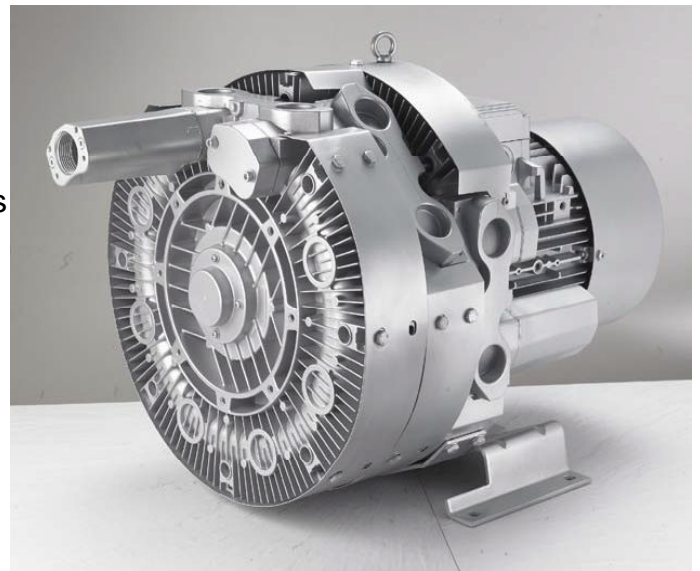

### Type for selection:

curve No	MODEL • In stock	Single double stage	Freq Hz	Output power Kw	voltage V	Rated current A	Max airflow m3/h	Max static suction mbar	Max static pressure mbar	Noise dB(A)	Dimension L X W X H mm	weight Kg
B282	• 4RB 630 H67	Double	50	7.5	345-415△	16.0△	170	-730	1040	72	710 X 442 X 457	85
B283			60	8.6	380-480△	16.0△	200	-700	1040	76		85